



## PERFORMANCE & BEVERAGE QUALITY

The AQ-RO series of Reverse Osmosis Systems is designed to deliver the highest quality water available by reducing a wide spectrum of contaminants, keeping your hot water equipment clean and improving your beverage quality.

Capable of removing the vast majority of contaminants from the incoming water supply, the AQ-RO is the perfect solution for applications that require a low amount of total dissolved solids. The high quality water produced by the AQ-RO will keep your equipment clean of sediment and other deposits, improving appearance and efficiency, and reducing down time due to cleaning. AQ-RO Reverse Osmosis systems are compact, wall mounted systems that can provide up to 600 gallons of water per day.



AQ-RO-600 System



### High Quality Water

3 stage treatment process filters sediment and chemical contaminants to prolong the operational life of the membrane



### Multiple Models

2 different models to accommodate different levels of water demand.



### Blend Value

The AQ-RO Systems allows you to dial in desired water quality.

# Reverse Osmosis | RO

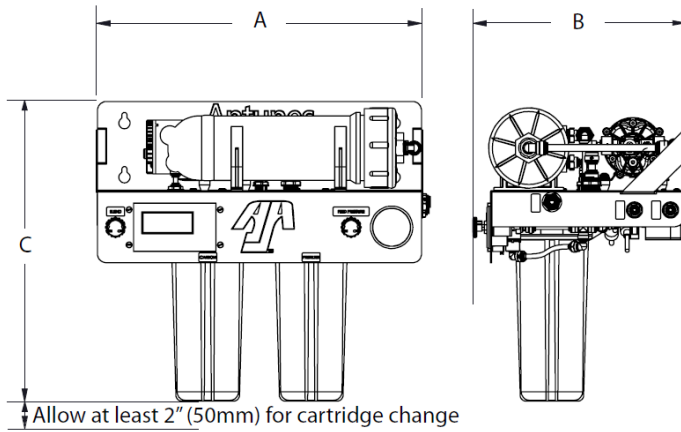

## Features:

- Display panel indicates product water TDS for accurate assessment of water quality
- Adjustable blend valve allows for fine-tuning of the product water TDS
- Three-stage treatment process filters sediment and chemical contaminants to prolong the operational life of the membrane

## Reverse Osmosis System Information

Model Mfg. No.	Width (A)	Depth (B)	Height (C)	Inlet	Permeate Line Size	Drain Line Size	Production Capacity	Motor	TDS Reduction
AQ-RO-600 9710144	18.5" (470 mm)	11.8" (230 mm)	16.6" (422 mm)	3/8" Tube (9.53 mm)	3/8" Tube (9.53 mm)	1/4" Tube (6.35 mm)	600 GPD (2271 LPD)	1/3 HP (0.25 kW)	96%



# H.E.R.O. System